

HIGH FLOW COMBINATION AFTERCOOLER/OIL COOLER



PRODUCT INFORMATION

- High Flows 2500 - 3500 CFM, Low Approach Temperatures, Reduces Dryer Size
- Cooler Rated for 500 to 600 HP Air Compressors
- Optional Hydraulic Motor, Low Noise Model Available
- One Aftercooler and One Oil Cooler Mounted in Steel Frame, Reduces Thermal Fatigue
- Competitive Pricing, Deliveries from Stock

COOLER DIMENSIONS

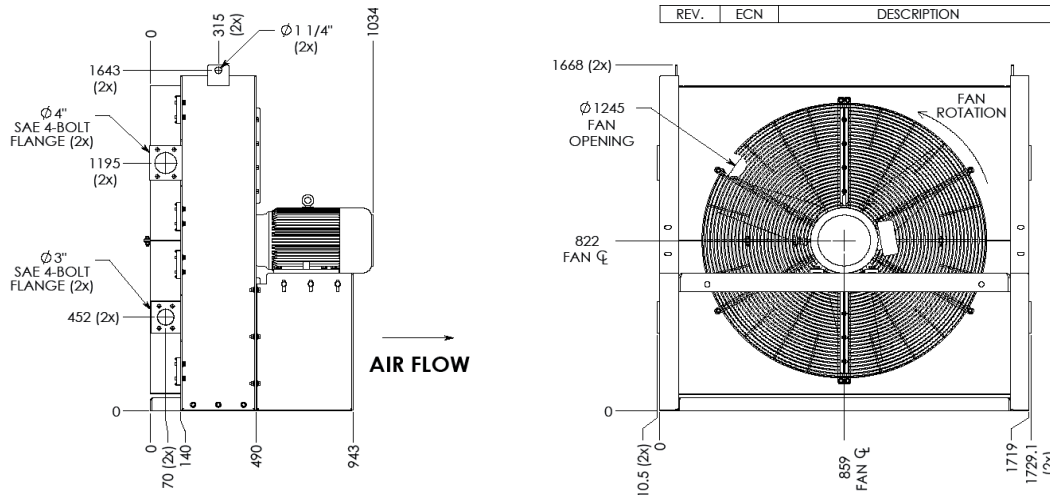

TECHNICAL DATA

INLET TEMP	2500 SCFM		3000 SCFM		3500 SCFM	
	APPROACH TEMP (F)	PRESS DROP PER COOLER (PSI)	APPROACH TEMP (F)	PRESS DROP PER COOLER (PSI)	APPROACH TEMP (F)	PRESS DROP PER COOLER (PSI)
150	2	1.7	4	2.4	5	3.2
200	5	1.7	8	2.4	11	3.2
250	7	1.7	12	2.4	16	3.4
300	9	1.7	16	2.6	21	3.5
350	12	1.8	20	2.7	27	3.6

SIZING/RATINGS BASED ON

- Max Pressure Rating - 250 PSI**
- Max Operating Temp - 350° F**
- Material - Aluminum**
- 100 PSIG Operating Pressure**
- 100° F Ambient Air**
- 1750 RPM Fan Speed**

ORDERING INFORMATION

AOC500 -

MOTOR CODE

- 0 = No Motor**
- 3 = Three Phase**
- 3EXP = Three Phase, Explosion Proof**
- 3L = Three Phase, Low Noise**
- 4 = Hydraulic Motor, 1.95 cu-in**